

## Framework Analysis of Smart House based on Orange Technology use Systematic Literature

A. Sudrajat<sup>\*1</sup>, Melyani<sup>2</sup>, Zahra<sup>3</sup> Hendra Kurniawan<sup>4</sup>, Didin Solehudin<sup>5</sup>, Dian Indah Sari<sup>6</sup>, Fazhar Sumantri<sup>7</sup>

Email: ([a.sudrajat.aut@bsi.ac.id](mailto:a.sudrajat.aut@bsi.ac.id)), ([melyani.myn@bsi.ac.id](mailto:melyani.myn@bsi.ac.id)), ([zahra.zzz@bsi.ac.id](mailto:zahra.zzz@bsi.ac.id)), ([hendra.hku@bsi.ac.id](mailto:hendra.hku@bsi.ac.id)) ([didin.dol@bsi.ac.id](mailto:didin.dol@bsi.ac.id)), ([dian.dhr@bsi.ac.id](mailto:dian.dhr@bsi.ac.id)), ([fazhar.fzs@bsi.ac.id](mailto:fazhar.fzs@bsi.ac.id))

Orcid: (0000-0002-3353-603), (0000-0003-0299-7142), (third author orcid)

<sup>1</sup>Techonology Informatic Faculty. University of Bina Sarana Informatika, Jakarta, Indonesia, 10450

<sup>2</sup>Economy and Business Faculty. University of Bina Saana Informatika, Jakarta, Indonesia, 10450

<sup>3</sup>Economy and Business Faculty. University of Bina Saana Informatika, Jakarta, Indonesia, 10450

<sup>4</sup>Economy and Business Faculty. University of Bina Saana Informatika, Jakarta, Indonesia, 10450

<sup>5</sup>Economy and Business Faculty. University of Bina Saana Informatika, Jakarta, Indonesia, 10450

<sup>6</sup>Economy and Business Faculty. University of Bina Saana Informatika, Jakarta, Indonesia, 10450

<sup>7</sup>Economy and Business Faculty. University of Bina Saana Informatika, Jakarta, Indonesia, 10450

\*Jl. Bunga Rampai VII GG.7 Rt.010 Rw.006 No.20 Perumnas Klende, Jakarta, Indonesia, 13860

### Abstract

Now days, the home environment is still much less supportive of life for the elderly, most elderly living at home need a companion to help them. Safety, health, happiness and independence will be difficult for them to get even the elderly will be further away from the surrounding environment. Based on population projection 2017 data there are 23.66 million elderly people in Indonesia and predicted in 2020 there are 27.08 million people elderly. Smart homes that are currently widely studied have not focused on elderly; most smart homes only provide a sense of security and convenience for adult residents. And this will be a problem that until now has not solved the improvement of human life through technology to get happiness, care and health especially for the elderly. In many cases of the elderly, it is easier to send them to live in a nursing home and that keeps them separated from their families for the rest of their lives. That's what makes them less happiness. Orange Technology is a collection of technological elements to improve human life by getting happiness, Care and health. This study reviewed the journals of scientific databases such as IEEE explore, ACM digital library and Proquest published from 2002 to 2017. From the search results obtained 54 papers that will answer the scientific questions of this research. The result of this research is a framework of smart house that has Sensor, Monitoring, Wireless, Scalability, Low cost, GPS and ease of installation and maintenance as components of smart house of orange technology for elderly.

**Keywords** Smart house , Framework, Systematic Literature , Analysis House

Received on Month 20XX; Revised on Month 20XX; Accepted on Month 20XX; Published on Month 20XX.

## I. INTRODUCTION

Orange technology is a field of interdisciplinary science research that is created to combine technological innovations and health technologies, happiness and care for human life [1] [2]. The scope of research includes computer science, electrical engineering, biomedical engineering, psychology / physiology, cognitive, communication, economics and social sciences [3] [4]. The orange technology comes from a red color guide (representing brightness, health and happiness) and yellow color (representing the warmth treatment) which is a color illustration of orange technology [1] [4]. The goal of orange technology is to provide more

DOI:

health, happiness, and care for people who emphasize the relationship between environment and human beings supported by technology.

How to safety and improve the human environment as we call it "House" to follow a healthy and happy life is to keep technology and orange computing at the same pace. In addition, orange technology must be developed in addition to smart technologies with the smart home to improve the life of a special group such as elderly people [3] [4].

The concept of smart house is specifically considered a necessary way to improvement home care for the elderly people [5] [6]. Smart House also offers an opportunity for seniors who want to live in their own homes without the help of others. In addition, smart homes can also help older people [7].

According to Government Regulation No. 43 of 2020, the elderly are someone who has reached the age of 60 (sixty) years and above[8] [9] . The composition of the old population growing rapidly in both developed and developing countries, this is due by declining fertility (mortality) and mortality (death), as well as increasing numbers life expectancy, which changes the structure of the population as a whole[10]. Process the occurrence of population aging is influenced by several factors, for example: increased nutrition, sanitation, health services, to the advancement of educational and socio-economic levels better[11] [12] .

Based on population projection data, it is estimated that in 2023 there are 50.66 million elderly people in Indonesia and year 2035 (48,19 million) [8] [9]. A state is said to be an old structure if has an elderly population of over seven percent (Soeweno). The figure below shows the percentage of elderly in Indonesia in 2024 has reached 12.03% of the total population.

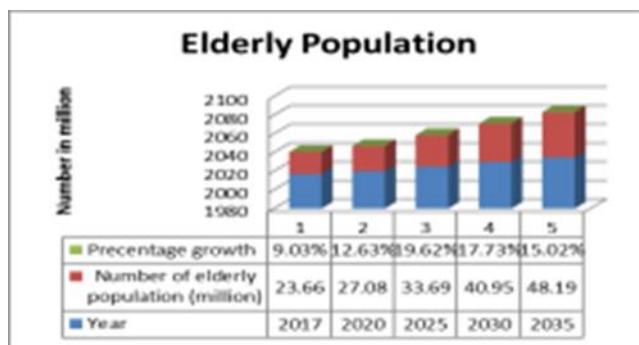

Fig. 1. Growth of elderly population

Source : Central Bureau of Statistics, SUSENAS 2023

Smart homes are human residential spaces designed specifically to enhance human life accompanied by interactive technology and non-intrusive support systems in order to support independence, daily activities and better welfare than provide others who help them [10] [11] .

Improvement of smart homes has elements of technology, engineering, ergonomics, management, communication, social assistance and safety[12]. Therefore, this study tries to define "What components are needed in smart homes using orange technology concepts for elderly people?. This result can made framework of smart home not only for people but elderly people can comfortable and improve their life. So the concept of orange technology brings more prosperity and human independence.

## II. LITERATURE REVIEW

### A. ORANGE TECHNOLOGY

Following to Babak Ziyae (2016) that Orange technology has elements like the carbon footprint used in technology; Orange Technology also has criteria for calculating health, happiness, and warming care. Such a characteristic can be used to evaluate people and products. And also, the orange model can be decomposed into three characteristics: health, happiness, and care [11]. The following content introduces an example of each indicator (see Figure 2).

In Orange technology has a basic purpose to improve humanities by using technology for social care to provide happiness for humans [12], especially for the elderly. Because things related to the environment and the elderly are a very important problem that should be sought a solution [13], and the other thing is to recommend a system to be used by the elderly as a design used in orange technology [14]. Orange technology has both physical and non-physical components. For physical components consist of: Sensor, GPS and Wireless while for Non-physical ones such as: Scalability, Monitoring, Low cost, easiness of installation and maintenance. The main goal of elderly health care is to be able to provide independence[15], comfort[16] and better communication as assistive technology[17] for the elderly so as to enable the two proposed components to improve the quality of life for the elderly[18]. And in this discussion the authors provide development for smart homes that can monitor elderly people so that they can be more independent[19]. This system uses artificial intelligence[20], multi sensors [21]and overall analysis of the needs and realities of users in receiving the proposed system[22]. The use of a number of sensors[12] [13] installed at home to measure the temperature of the room[23], knowing who came and entered the house[24], measured the light[25], the amount of power used[26]. The device used in the house is connected to a computer that is used to identify daily habits with multi-sensing data[27].

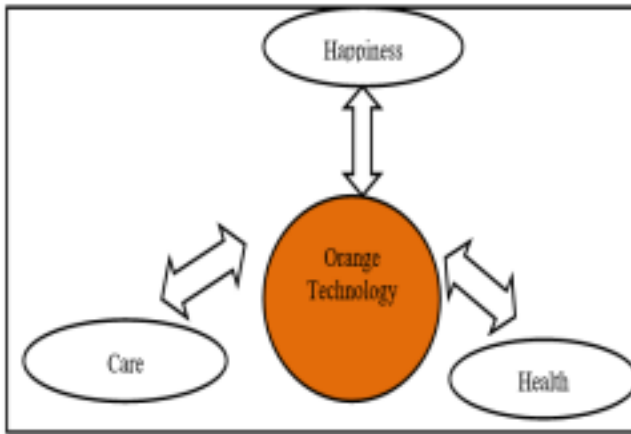

Fig.2.Characteristics of Orange Technology

Source : Ziyae(2021)

### B. Elements of Orange technology

This review seen that elements Care has 26 papers which reviewed in this element, and another element such Happiness has 15 articles reviewed, for Health has 13 articles reviewed in this study research. (Seen in Table I)

Table I. Element of Orange Technology

Elements of Orange Technology	# of papers	#papers
Happiness	15	[7];[10];[17];[18];[22];[24];[26];[32]; [37];[38];[43];[44];[47];[54]
Health	13	[2];[4];[15];[19];[23];[25];[28];[29];[50]
Care	26	[1];[3];[5];[6];[8];[9];[11];[12];[13];[14];[16];[20];[27];[30];[31];[33];[34];[35]; [36];[39];[40];[41];[42];[45];[46];[48]; [49];[51];[52];[53]

Source : Result of Research,2025

#### 1. Happiness

For people or products: Electrical sensors are used to recognize and record the amount of laughter and smiles produced by a person [7] [10]. In fact, personal emotions can be used for product measurement. When tastes use the product, the footprints of happiness [17][18], for example, Dopamine[22], are measured through their experience with sensors, equipment [24], or just a questionnaire [26] . The body temperature [38] [43] [44] . So all the information is

combined and then can know and determine the level of happiness which is a quite challenging task[47]

[54] .

## 2. Health

For people or products: The index includes toxic substances in products or substances secreted by the human body [2] [4] [15] [19]. For health elements have medical contributions, usually when users need expert input [23], and then a system will seek and consult with a medical / physician [25][28] [29] Then all the information input from the medical expert is combined and entered into the knowledge database, and the system will provide the information according to the demanded requirements appropriately [50].

## 3. Care

Orange Transform: Any production or non-orange design can be converted to orange computing as long as it adds three orange computing factors, including the characteristic of happiness, health and care, into the process or itself.

Furthermore, all characteristics must be higher than the specified threshold. Element treatment / warming treatment [1] [3] [5] is an element that has an important role in orange computing [6] [8] [9] [11] [12] [13] [14] [16] [20] [27]because of the many questions will be who the user [30] [31], how the user get a fast response[33] [34] [35] [36] [39] [40]and when the response is received by the user appropriately in order to require a system of understanding that semantic[41][42] [45] and accurate which is part of Human interaction - computer (Human Computer Interaction) [46]. Real examples of element Care such as: charitable donations[48]; social workers[49]; retirement home [51] [52] [53]and these examples can be selected in an element of Care.

## II. RESEARCH METHOD/METHODOLOGY

This study was conducted by reviewing the comprehensive literature of previous studies on orange technology in smart homes for framework design for elderly people [8][9]. The search process in this study by determining several keywords through literature review, initiating inclusion and exclusion criteria, extracting data and analyzing the findings to answer research questions [24].

## **A. Literature Process**

The first way to do is to determine the literature source to find the right article / document. Sources selected for systematic review of literature are as follows:

- ACM Digital Library ( <https://dl.acm.org>)
- AIS Electronic Library (<https://aisel.aisnet.org>) •Emerald Insight (<https://emeraldinsight.com> )
- IEEE Xplore Digital Library (<https://ieeexplore.ieee.org>) •Science Direct (<https://sciencedirect.com>)
- ProQuest ([www.proquest.com](http://www.proquest.com))
- NCBI (<https://ncbi.nlm.nih.gov>)
- Springer link (<https://link.springer.com>)
- Taylor Francis (<https://taylorandfrancisonline.com> )

## **B. Inclusion and exclusion criteria**

The inclusion criterion of the search mechanism consists of Study Found, Candidates studies and Selected Studies. The first is the process of "Study Found". The research of this study based on 10 scientific databases show the required components of smart home for older people in orange computing generates 2377 papers. Then deleted duplicate journals and generated 386 papers that were identified, deleted 289 irrelevant papers titles resulted in 97 papers corresponding to abstractions, so the number of papers used to answer research questions there are 54 papers to be reviewed.

To obtain the validity of the existing literature in this study, have a search exclusion criteria defined in several respects, as follows:

- Documents by date of publication are from 2002 to 2018 •The completed paper, which means that all data in paper review (journal / conference, author's identity, etc.) are mentioned in the document.
- The duplicated of the same study published in this literature review is omitted.

## **C. Extract Data**

This study paper has examined 386 papers from several sources and criteria. There are 97 papers selected as candidate studies that have corresponding to the related title and a summary of the research objectives. After investigated obtained 54 papers used for the review in this study.

### III. RESULT/FINDINGS AND DISCUSSION

#### A. *Result*

This study aims to investigate the components of orange technology in smart home for the elderly people. Based on a review of 54 documents, it can be defined that framework of smart home has 7 components using orange technology for the elderly people, namely: Scalability, low cost, sensor, monitoring, wireless, GPS and installation and maintenance facilities maintain a smart home to support health, safety and independence. Regarding 7 components researcher propose 2 parts namely: Wearable unit and Non-physical unit. The discussion is as follows:

#### A. Wearable Unit

The unit that can be used is a tool used by the elderly in the house. Components included in the wearable unit that is: Sensor, Wireless and GPS as follows:

##### 1) Sensor

Sensors are implemented in Smart House to monitor occupant safety and provide various services. Environmental sensors are used to detect interactions between users and objects to help recognize human everyday activities [4][6][9] [12][13] These include sensors embedded in beds, chairs, kitchen utensils, etc [20] [27]. Motion sensors detect motion and comprise optical sensors, microwaves, infrared, acoustics, bracelet, etc [34] [41] [45] [46]. Motion sensors can be seen as applications that can provide peace for the inhabitants, and generally do not disturb the occupants[48] [53].

##### 2) Wireless

A wireless motion sensor network is also used, where some of them are coupled with a contact sensor on the door. The infrared wireless coverage sensor is used in the Home Monitoring System (IMS) [5] [8] [14]. This motion sensor can be used in Smart House for safety detection and falls for adults, user tracking, and behavioral pattern analysis [16] [30] [39]. The infrared motion sensor is used to record the movement of the occupants[42] [51] . This infrared sensor is placed in all rooms in smart home. Magnetic contact sensors are also placed in the door to "track the flow of visitors" or to track if someone is home.

##### 3) GPS(Global Positioning System)

Home-installed technology is self-sufficient positions Users have different types of devices for home automation and home control [11], such as:

##### 1) Automatic kitchen appliances;

- 2) Lamp and door control;
- 3) Indoor temperature controller;
- 4) Water temperature controller;
- 5) Home security device.

Please note that automatic kitchen appliances include washing machines, programmable electric ovens, dishwashers, etc [21] [36]. In cases where the device is manipulated by older people[40] [52], an appropriate interface should be provided.

### **B. Non – Physical**

Non-physical components are needed non-material such as: Monitoring, Scalability, Low cost and easiness of maintenance. Therefore, these components are indicators that are needed so that the elements of happiness and health are obtained by the elderly who live in their homes.

#### 1) Scalability

Scalability is indicator of the device / system used to measure a person's ability level[1] [10] [18], especially for the elderly [24] [26]who can help carry out daily activities at home so that these components become part of the smart home [50] [54].

#### 2) Monitoring

Smart homes are equipped with equipment for home remote monitoring (such as room temperature monitoring, room humidity, and smoke detection) [2][19][23][25] and very important physical conditions such as heart rate, body condition, blood pressure as well as room oxygen pressure and occupant activity[28][31] [33] . Thus, it can be known and monitored physiologically [35]by others and this component is very helpful for elderly [49]to receive assistance if needed.

##### a. Low Cost

The use of smart homes at low cost [7] [17] [22]can allow elderly to live comfortably rather than using expensive and limited health facilities, and this is a component they have to provide a comfortable home for the elderly people[32] [37][38] .

##### b. Easiness of installation and maintenance

Smart homes for the elderly people should be designed to meet the criteria of one of its components [3] [15] [29]: the level installed in the smart house has the installation facilities and

also the necessary maintenance [43]so that the machine can help the residents according to your needs and the smart house destination can be achieved to provide a home comfortable[44] [47], healthy and self-sufficient that also meet the health, care and happiness features of the orange technology.

### **C. Framework Analysis**

Following the above review literature, a proposed framework for smart house components is composed of two parts: Non-physical and Wearable units. Components included in the Wearable unit: (Sensor, Wireless, GPS). The unit / tool used are used to collect information on the movement and activity of human subjects. The unit used is to collect information about physiological activities and the body through sensors and wireless. The data from the environment and the GPS used are processed by the home gateway where pre-processing, indoor localization through a collection of server databases and the results of the activity recognition algorithms that have been implemented. Physiological data sent comprehensively with contextual information is then sent to a private website for storing and locating local and remote access.

Meanwhile, non-physical components of the results obtained from the tool (Wearable unit) is sent to the personal website as a way to monitor physically occurring in the house, and also this technology used as scalability measurement of health from day to day. Constraints that often occur that a technology is created at a price that is not affordable by people in need so that the technology cannot be used directly by the intended target. Orange technology has the elements of creating happiness and health monitoring. And the components that are not less important in the non-physical namely the ease of maintenance so that the tools are installed or used easy to repair. (Seen in Figure 3).

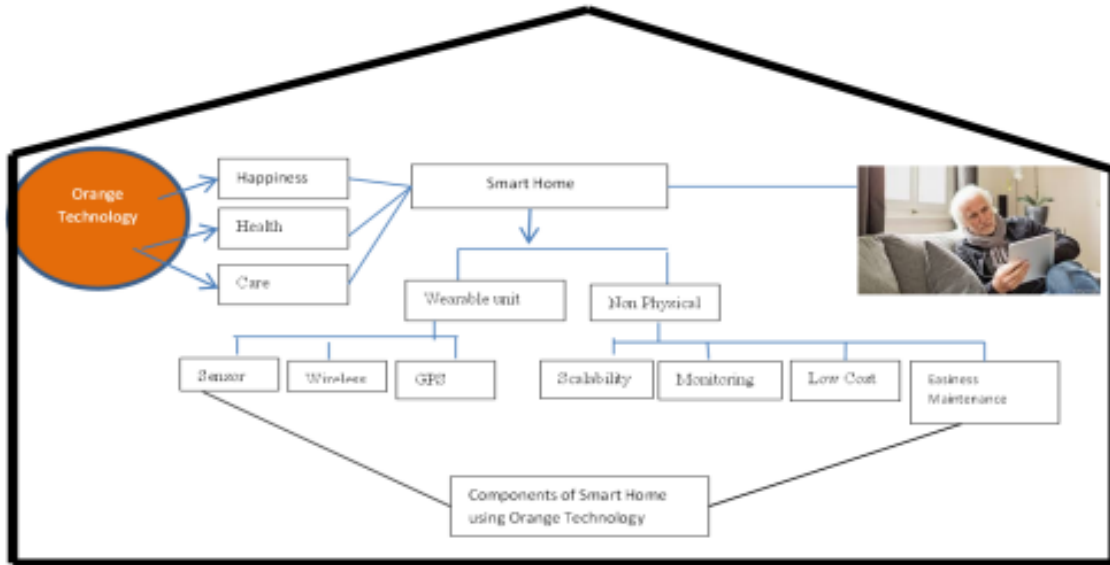

Figure3. Framework analysis of component smart house on orange technology.

Source : Result of Research,2025

#### D. Proposed Sensor for Smart House

The use of sensors installed in smart homes for the elderly, so there are two parts consisting of electronic goods and other electrical goods and sensors installed in each room (see figure 4).

a. Each electronic and electricity item will be connected to the remote control and for sensors connected to the control panel in the form of a Binary Unit system which is used as a link between the computer PC and the sensor device installed.

b. Monitoring equipment in the form of a PC computer consisting of a monitor screen and keyboard. PC computers are used as servers in storing databases that have been stored in the form of habits and normal circumstances that occur in the house.

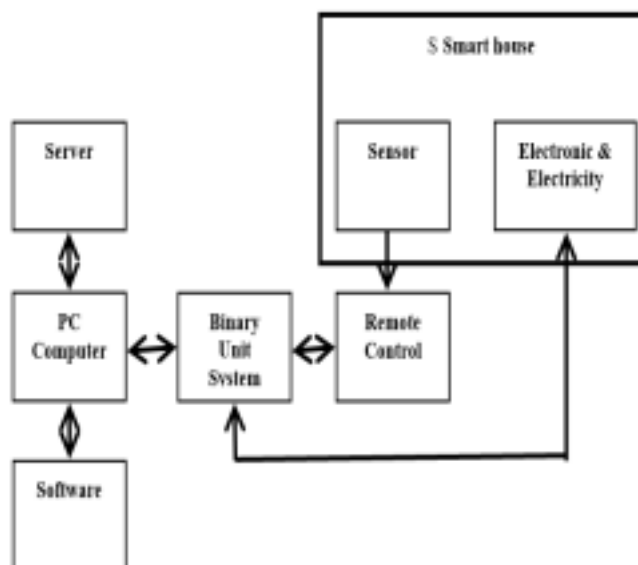

Figure 4. Proposed Sensor for Smart House

Source : Result of research,2025

This PC is also used to store all activities that occur in the occupants of the house and this is called the control panel in figure 4. This PC computer uses software to monitor the habits that occur, decision making and as a basis for diagnosis of the occupants of the house, and this PC computer also as an interface tool to monitor the occupants of the house, namely the elderly who are connected with electronic devices and electricity that has been connected.

#### IV. CONCLUSION AND RECOMMENDATION

The conclusion that can be drawn from this research is that smart house needed by elderly people have seven components from orange technology are Scalability, low cost, sensor, monitoring, wireless, GPS and installation and maintenance. Implications consist of theory and practice. Theoretical implications for science are the new concepts of orange technology for health, happiness and humanistic care [1] [17] . This concept emphasizes the relationship between environments, human as well as technology. Orange computing focuses on the design of procedures and systems to improve the balance of body and mind[18] . Implications of practice that can be applied in housing to support and provide comfort, independence, welfare and ease of life for the elderly people [19] [20], so that this research framework will improve life at home and help them if needed.

#### LIMITATIONS AND FUTURE RESEARCH

The limitation of this studies is that data from articles obtained from research databases has been long, since the articles used should last 5 years, while this article reviews data from 16 years ago. Therefore, this review also includes 54 articles on concept or theories of analytical methods. The main purpose of this table is to provide framework designs for smart home that are analyzed for parents or older people in the last 16 years according to the search in the database. The smart home component of identified orange technology has many areas to consider for future research. The components needed in smart homes for the elderly person is the conceptual components, while subject health therapy for elderly will be further investigation.

## REFERENCES

- A. Altendorf and J. Schreiber, "Assistive technology in dementia care: Methodological issues in research design," *J. Assist. Technol.*, vol. 9, no. 1, pp. 38–47, 2015.
- Arman, A., Prasetya, P., Arifany, F. N., Pradnyaparamita, F. B., & Laksito, J. (2022). A Digital Printing Application As An Expression Identification System. *Journal of Technology Informatics and Engineering*, 1(2), 5–15. <https://doi.org/10.51903/JTIE.V1I2.135>
- A. Aspinall, "How can assistive technology and telecare support the independence and employment prospects for adults with learning disabilities?," *J. Assist. Technol.*, vol. 1, no. 2, pp. 43–48, 2021.
- A. L. Bleda, F. J. Fernandez-Luque, A. Rosa, J. Zapata, and R. Maestre, "Smart Sensory Furniture Based on WSN for Ambient Assisted Living," *IEEE Sens. J.*, vol. 17, no. 17, pp. 5626–5636, 2019.
- D. J. Brown, "Some uses of educational and assistive technology for people with disabilities," *Comput. Educ.*, vol. 56, no. 1, p. 56, 2011.
- H. S. Al-Khalifa, M. Al-Twaim, M. Al-Mohsin, and M. Al Razgan, "Technologies Developed for Older Adults: Trends and Directions," *Commun. Comput. Inf. Sci.*, vol. 435 PART I, pp. 279–283, 2020.
- J. Abascal, B. Bonail, Á. Marco, R. Casas, and J. L. Sevillano, "AmbienNet: an intelligent environment to support people with disabilities and elderly people," *Proc. 10th Int. ACM SIGACCESS Conf. Comput. Access.*, pp. 293–294, 2021.
- J. Berner et al., "Factors influencing Internet usage in older adults (65 years and above) living in rural and urban Sweden," *Health Informatics J.*, vol. 21, no. 3, pp. 237–249, 2019.

- Li, Q., Diao, Y., Chen, Q., & He, B. (2022). Federated Learning on Non-IID Data Silos: An Experimental Study. *Proceedings - International Conference on Data Engineering, 2022-May*, 965–978. <https://doi.org/10.1109/ICDE53745.2022.00077>
- M. A. O. Brien, W. A. Rogers, and A. D. Fisk, “Understanding Age and Technology Experience Differences in Use of Prior Knowledge for Everyday Technology Interactions,” vol. 4, no. 2, 2022.
- Qin, Y. (2023). Semantic Role Labeling in Neural Machine Translation Addressing Polysemy and Ambiguity Challenges. *Journal of Technology Informatics and Engineering*, 4(1), 41–55. <https://doi.org/10.51903/JTIE.V4I1.274>
- Santoso, J. T., Manongga, D., & Hendry, H. (2025). Decision support system in machine learning models for a face recognition-based attendance system. *TELKOMNIKA (Telecommunication Computing Electronics and Control)*, 23(2), 371–381. <https://doi.org/10.12928/TELKOMNIKA.V23I2.26412>
- Santoso, J. T., Wibowo, A., & Raharjo, B. (2024). Enhancement of Internal Business Process Using Artificial Intelligence. *Jurnal Nasional Pendidikan Teknik Informatika (JANAPATI)*, 13(3). <https://doi.org/10.23887/janapati.v13i3.79242>
- Santoso, J. T., Wibowo, A., & Sulartopo, S. (2024). THE EFFECT OF COVID-19 ON THE STABILITY OF THE FINANCIAL INDUSTRY. *International Journal of Professional Business Review*, 9(7), e02920. <https://doi.org/10.26668/businessreview/2024.v9i7.2920>
- Wibowo, A. (2023). *Layanan FinTech dalam Perspektif Hukum, Ekonomi, Teknologi (First)*. YPAT.
- Wibowo, A., & Listyarini, D. (2023). *Hukum Pemerintah*.
- Wibowo, A., & Santoso, J. T. (2024). Bottled Water Purchase Decisions: A Study of Brand Image as a Green Marketing Medium in Purchase Decisions. *International Journal of Supply and Operations Management*, 11(1), 83–99. <https://doi.org/10.22034/IJSOM.2023.110194.2961>